



Product Information

DRILLMASTER 100 EH/DH

RDH 100 EH (Electric Hydraulic) & DH (Diesel Hydraulic)
for narrow vein application

The DRILLMASTER 100 Series was designed and manufactured to meet the toughest mining environments. Featuring a Clark Power Shift transmission with 3 forward and 3 reverse gears this jumbo travels the mine with ease. Boasting an overall width of only 1321 mm it is capable of drilling in narrow vein headings as well as large headings due to its boom coverage.

For ease of maintenance and repair the DRILLMASTER 100 Series was designed with the mechanic in mind, providing easy access and removal of all components.



The DRILLMASTER 100 series features a solid frame with a low center of gravity, giving the Drillmaster the ability to operate on uneven surfaces and rough conditions. This feature coupled with its power shift transmission elevates this new Drillmaster Jumbo to a class of it's own.

This unit is fitted with RDH'S own unique drill control manifold which features some of the newest hydraulic technology available.

In short the DRILLMASTER 100 series provides mining companies the ability to operate one single boom jumbo in both narrow vein production headings as well as larger development headings without the high cost of having two jumbos.

RDH DRILLMASTER LONGHOLE

TECHNICAL SPECIFICATIONS

RDH 100 Drillmaster Longhole for narrow vein application

Features

- Compact narrow vein jumbo 1270 mm wide
- Power shift transmission
- 1 m Telescopic boom with a 360° Rotation Slide
- Anti-Jamming function and semi-automatic collaring
- Compact unit with high mobility and drilling power
- Re-indexing positioner to allow Roof Bolting, Benching and drilling into both ribs (Option)
- Fenders and Operators Compartment are Bolt-On
-

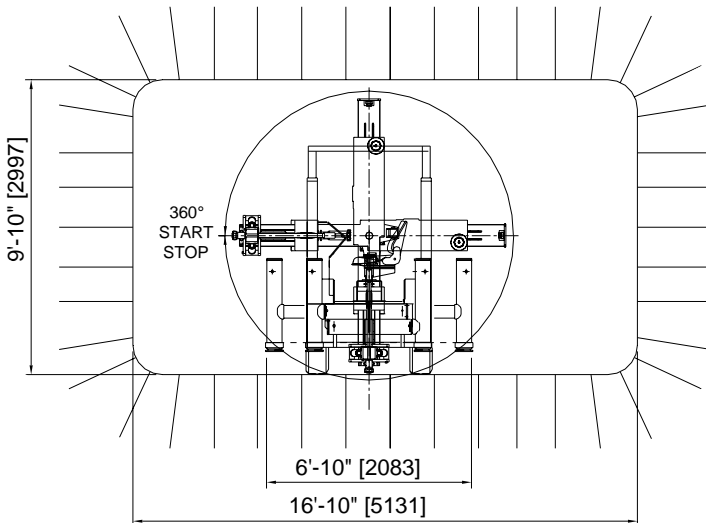
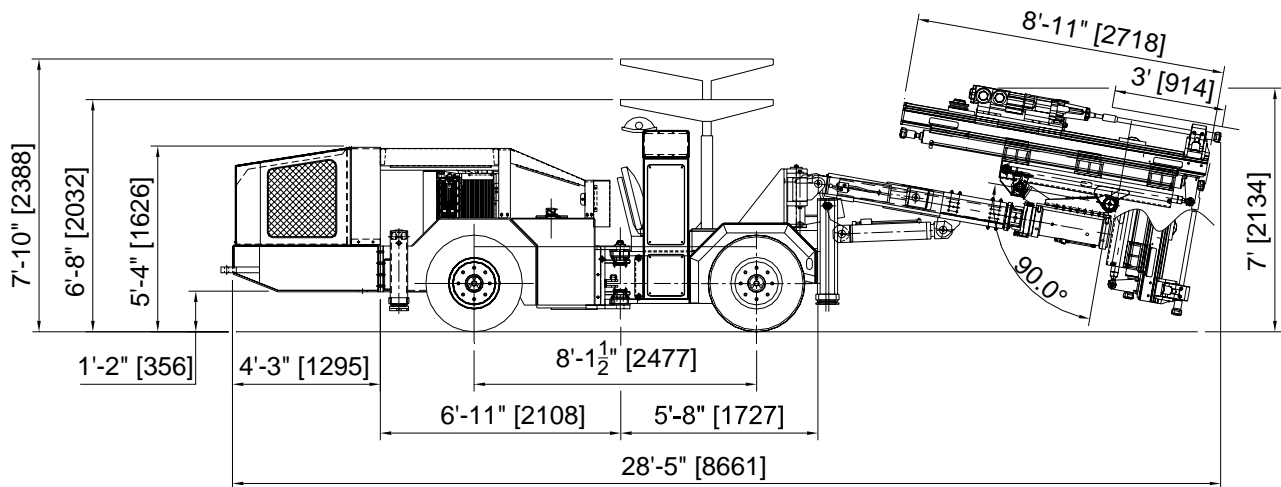
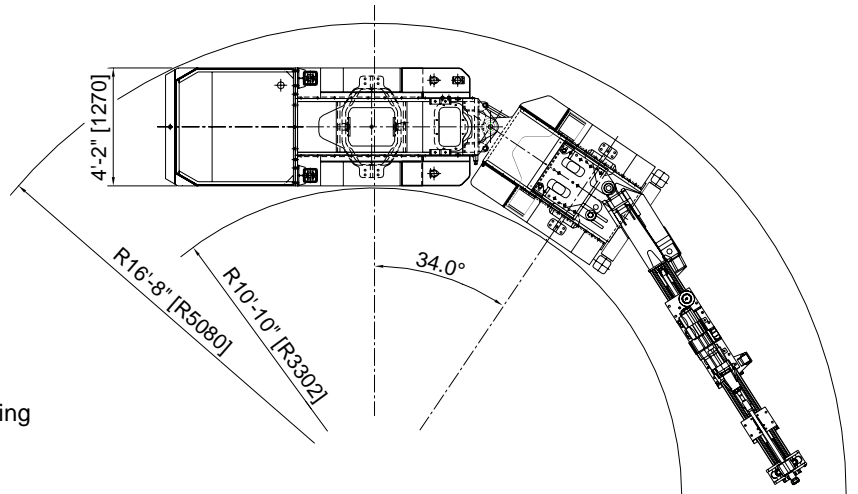

Drill Rig Face Coverage Pattern

Carrier

Engine	Deutz 4 Cyl. Air Cooled, BF4L914
	Ratings: (110 HP) 2300 RPM
Transmission	Clark HR 20,000 series, Powershift
	Speed: 3 Forward, 3 Reverse
Axles	Ford D45N
Brakes	Totally enclosed Wet Disc
Electrical	24 volt negative ground
Tires	14:00 X 17.5 14 Ply or 10.00 X 15 14 Ply

Options:

Drifter	109 Montabert
Feed	F3, F4, F5, F6, F8, F10, F12
Drilling	Electric or Diesel Hydraulic Drilling
Tires	Gel Filled
Electrical	550 Volts, 50 Hz
High Voltage	



Manufactured by:
 RDH Mining Equipment
 P.O. Box 188, 904 Hwy 64
 Alban, Ontario, Canada P0M 1A0
 Tel: (705) 857-2154 Fax: (705) 857-3285
 Email: sales@rdhminingequipment.com
 Website: www.rdhminingequipment.com

ISO 9001-2000
 REGISTERED

CWB
 CERTIFIED